

Table 48x24



No Tools
Required



2 People
Required



Holds up to
300 lb (136 kg)

vari®

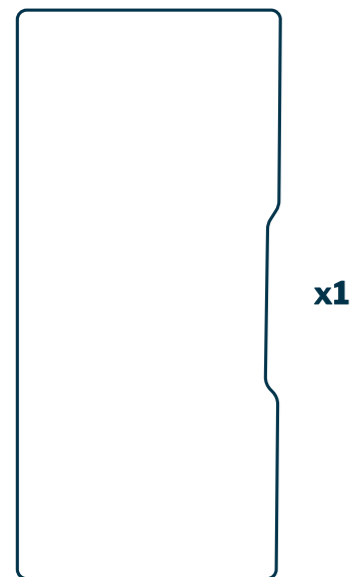

x1

1

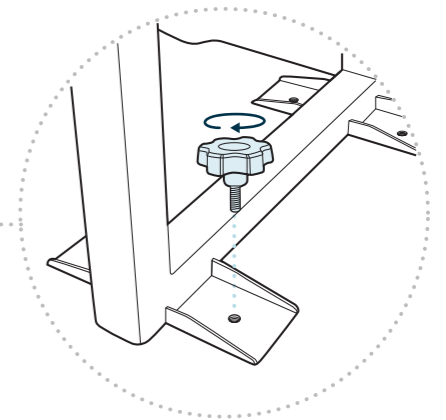
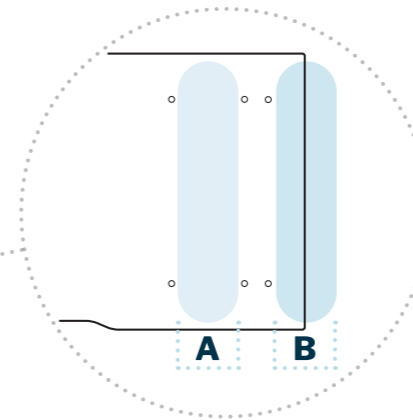
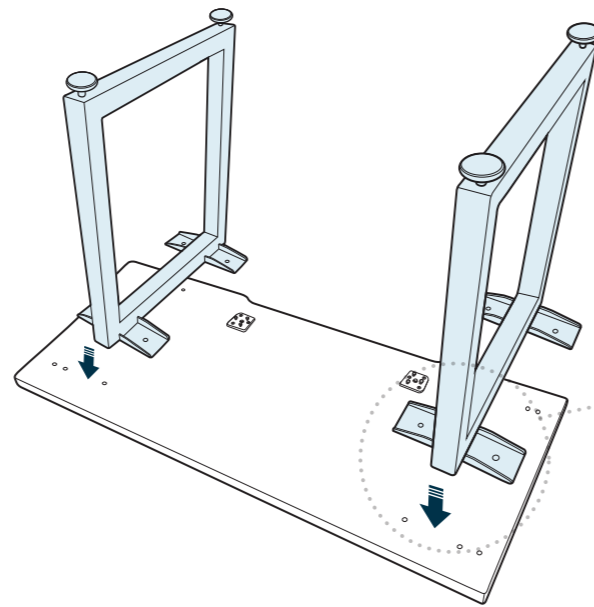
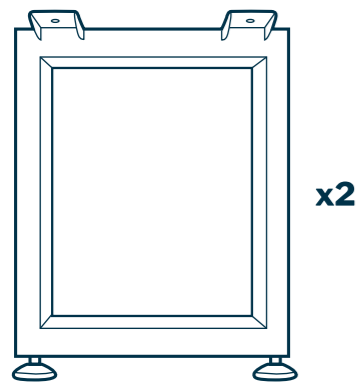

Table top and table legs will arrive in separate boxes. We recommend assembling the table face down in the box to prevent any surface scratching. Unbox the legs and line up legs with desired connection points.

There are two rows of connection points. "A" is our recommended setup, and "B" is for 2 linking desks together. Use the hand bolts to fasten the legs to the table top and tighten until firmly in place.



x2

2

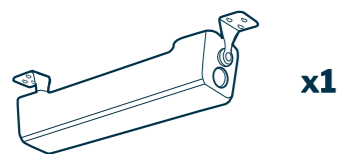
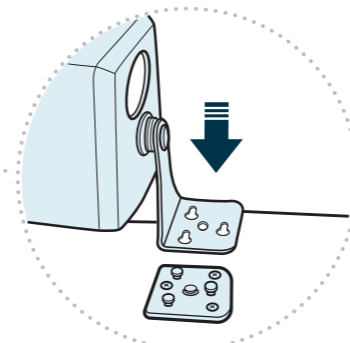
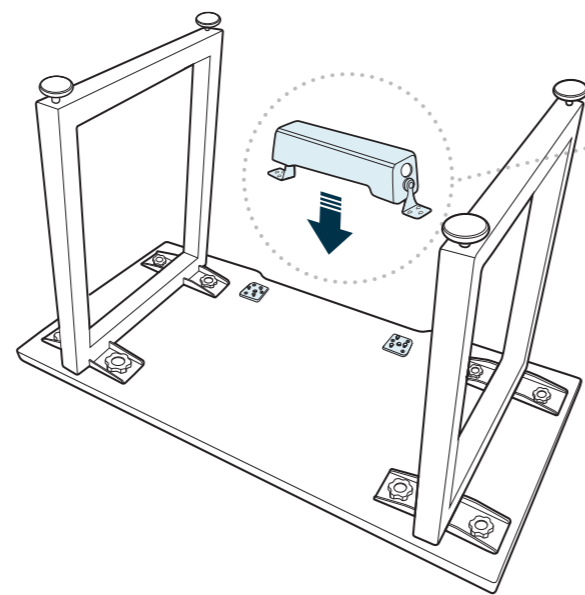

x1

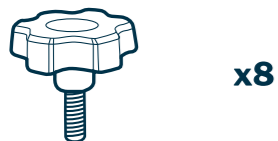

x8

Slide the cable management tray into the notches at the edge of the table and push until it clicks, indicating it is locked into place.

3

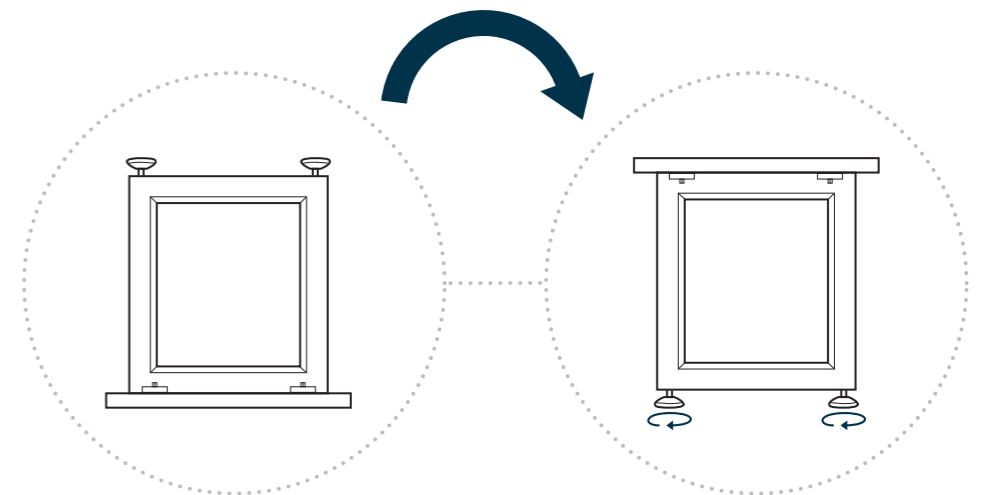

Two people should lift and flip the assembled table to an upright position. Adjust the footpads to level table as needed.

Linking Multiple Tables

To link 2 desks together, you will only need 3 legs — only one leg at each connection point. Refer to the illustration of the “B” connection points for placement.

